

19SV VANGUARD TRAILER

G.V.W.R. 1,995#	AXLE 2000# EZ LUBE
G.A.W.R. 2,000#	SUSPENSION Multi-Leaf Spring
COUPLER 2" A-Frame	TIRE ST175/80-13" Load Range B
SAFETY CHAINS ¼" Grd. 30 w/Safety Latch Hook (2 ea.)	WHEEL 13 X 4.5 White Spoke 5 Bolt
JACK 2000# Top Wind (Bolted On)	FLOOR 2" Pine
TONGUE 3" Channel V-Tongue	LIGHTS D.O.T. Stop, Tail, Turn and Clearance
TOP RAIL 1" X 2" Rectangle Tubing	ELEC. PLUG 4 Way Flat w/ Loom
FRAME 2" X 3" X 3/16" Angle	FINISH (PREP) Acid Etched w/White Phosphorus, Under-coated w/Panther 813 & Two Coats Primer
CROSSMEMBER 2" X 2" X 1/8" Angle	FINISH Painted w/ 2 Coats High Solid <i>Supreme</i> Acrylic Automotive Grade Enamel, and Pinstriped
UPRIGHTS 1" X 2" Rectangular Tubing 26½" Tall	
FENDERS 8" X 28" Rolled Formed	

STANDARD FEATURES

- Safety Chains Attached w/ Cold Rolled Eyelets
- Lower Jack Support Plate
- Ez Lube Axle
- 27½" Sides w/ 24" V-Crimped Steel Panels
- 2½" Opening for Easy Tie Down
- 1" X 2" Tubular 3' Tall Expanded Metal Rampgate
- White Spoke Wheels

19SV-8

DIMENSIONS			
LENGTH	A	B	C
8'	97-1/2"	40-1/2"	57"

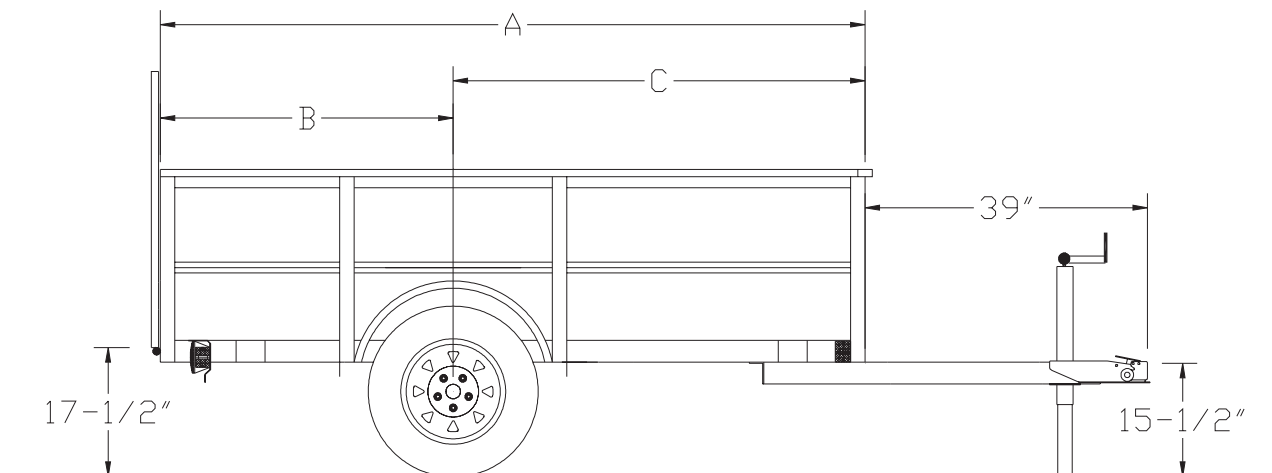

PRICING

MODEL #	WEIGHT	DESCRIPTION	
19SV-8	800#	50" X 8' Single Axle Vanguard	

OPTIONS

Spare Mount (Side)	
13" Spare Tire & Wheel	

Prices Effective January 1, 2005

© 2005 Copyright by Big Tex Trailer Manufacturing, Inc.