

# SINGLE AXLE ALL-AROUND TRAILER

|                      |                                                 |                      |                                                                                              |
|----------------------|-------------------------------------------------|----------------------|----------------------------------------------------------------------------------------------|
| <b>G.V.W.R.</b>      | 2,995#                                          | <b>AXLE</b>          | 3500# EZ LUBE w/ Brake Flanges                                                               |
| <b>G.A.W.R.</b>      | 2,960#                                          | <b>SUSPENSION</b>    | Multi-Leaf Spring                                                                            |
| <b>COUPLER</b>       | 2" A-Frame                                      | <b>TIRE</b>          | ST205/75-15 Load Range B                                                                     |
| <b>SAFETY CHAINS</b> | 1/4" Grd. 30 w/Safety Latch Hook (2 ea.)        | <b>WHEEL</b>         | 15 x 5 White Spoke 5 Bolt                                                                    |
| <b>JACK</b>          | 2000# Top Wind (Bolted On)                      | <b>FLOOR</b>         | 2" Pine                                                                                      |
| <b>TONGUE</b>        | 3" Channel                                      | <b>LIGHTS</b>        | D.O.T. Stop, Tail, Turn and Clearance                                                        |
| <b>SIDES</b>         | (14 Ga.) 14" Solid Formed Side Panels w/ 2" Lip | <b>ELEC. PLUG</b>    | 4 Way Flat w/ Loom                                                                           |
| <b>FRAME</b>         | 2" X 3" X 3/16" Angle                           | <b>FINISH (PREP)</b> | Acid Etched w/White Phosphorus, Undercoated w/Panther 813 & Two Coats Primer                 |
| <b>CROSSMEMBERS</b>  | 2" X 3" X 3/16" Angle                           | <b>FINISH</b>        | Painted w/ 2 Coats High Solid <i>Supreme</i> Acrylic Automotive Grade Enamel, and Pinstriped |
| <b>FENDERS</b>       | 9" X 32" Rolled Formed                          |                      |                                                                                              |

## STANDARD FEATURES

- Six Tie Down Rings On Sides
- 4 Ft. Tubular Rampgate w/ Expanded Metal, & Knife Edge
- Ez Lube Axle
- Floor Secured w/ 5/16" Torx Screws
- Safety Chains Attached w/ Cold Rolled Eyelets
- 14" Solid Formed Sheet Sides
- Lower Jack Support Plate
- White Spoke Wheels

### 30AA-10

| DIMENSIONS |          |         |     |
|------------|----------|---------|-----|
| LENGTH     | A        | B       | C   |
| 10'        | 121-1/2" | 48-1/2" | 73" |

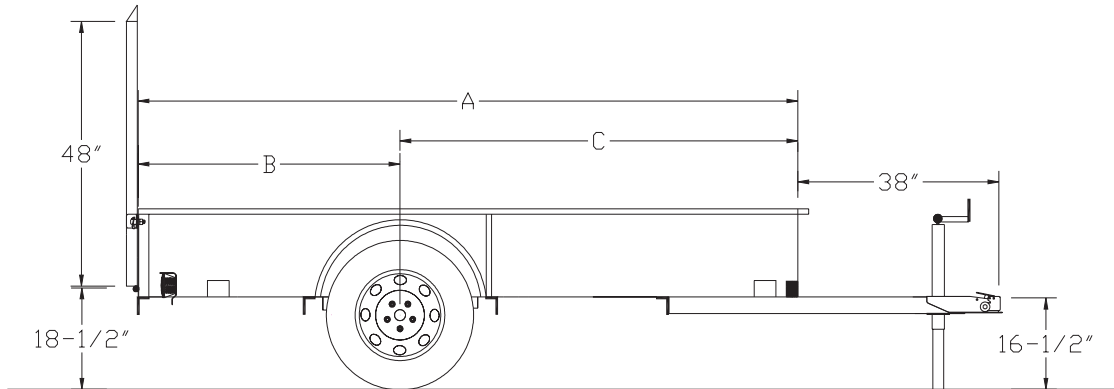

## PRICING

| MODEL # | WEIGHT | DESCRIPTION                      |
|---------|--------|----------------------------------|
| 30AA-10 | 850#   | 60" X 10' Single Axle All Around |
| 35AA-10 | 1160#  | 77" X 10' Single Axle All Around |

## OPTIONS

|  |                                                                              |  |
|--|------------------------------------------------------------------------------|--|
|  | Electric Brakes on One Axle (Includes complete break-a-way system w/charger) |  |
|  | Spare Tire Mount (Side)                                                      |  |
|  | 15" Spare Tire & Wheel                                                       |  |
|  | 2" Bulldog Coupler                                                           |  |
|  | Fold-Up Jack                                                                 |  |
|  | Set Back Jack                                                                |  |