

SINGLE AXLE VANGUARD TRAILER

G.V.W.R.	2,995#	AXLE	3500# EZ LUBE w/ Brake Flanges
G.A.W.R.	2,960#	SUSPENSION	Multi-Leaf Spring
COUPLER	2" A-Frame	TIRE	ST205/75-15 Load Range B
SAFETY CHAINS	¼" Grd. 30 w/ Safety Latch Hook (2 ea.)	WHEEL	15 x 5 White Spoke 5 Bolt
JACK	2000# Top Wind (Bolted On)	FLOOR	2" Pine
TONGUE	3" Channel	LIGHTS	D.O.T. Stop, Tail, Turn and Clearance
TOP RAIL	1" X 2" Rectangle Tubing	ELEC. PLUG	4-Way Flat w/ Loom
FRAME	2" X 3" X 3/16" Angle	FINISH (PREP)	Acid Etched w/White Phosphorus, Undercoated w/Panther 813 & Two Coats Primer
CROSSMEMBERS	2" X 3" X 3/16" Angle	FINISH	Painted w/ 2 Coats High Solid <i>Supreme</i> Acrylic Automotive Grade Enamel, and Pinstriped
UPRIGHTS	1" X 2" X 26½" Tall Rectangle Tubing		
FENDERS	9" X 32" Rolled Formed		

STANDARD FEATURES

- 27½" Tall Sides w/ 24" V-Crimped Steel Panels
- 2" Tubular 4' Tall Expanded Metal Rampgate w/ Knife Edge
- Lower Jack Support Plate
- 2½" Opening for Easy Tie Down
- Floor Secured w/ 5/16" Torx Screws
- Top Rail Capped w/ Self Sealing Plugs
- Ez Lube Axle
- 4-Rope Rings - 2 each Side Inside

30SV-10

LENGTH	DIMENSIONS		
	A	B	C
8'	97-1/2"	36-1/2"	61"
10'	121-1/2"	48-1/2"	73"
12'	145-1/2"	60-1/2"	85"
14'	169-1/2"	72-1/2"	97"

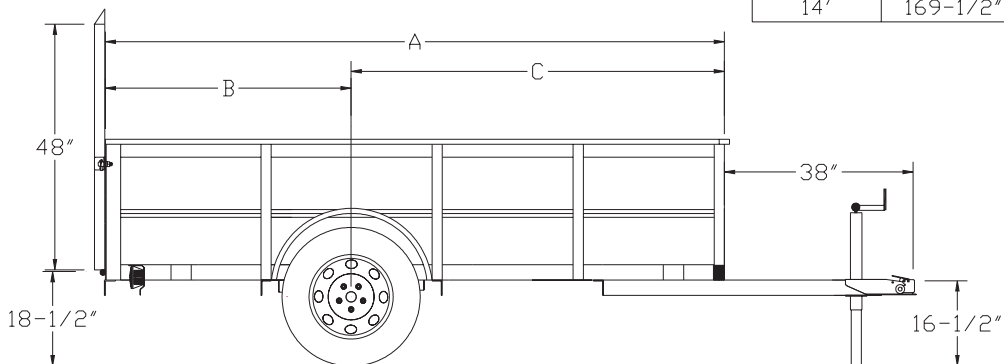

PRICING

MODEL #	WEIGHT	DESCRIPTION
30SV-8	850#	60" X 8' Single Axle Vanguard
30SV-10	1060#	60" X 10' Single Axle Vanguard
30SV-12	1270#	60" X 12' Single Axle Vanguard
35SV-10	1160#	77" X 10' Single Axle Vanguard
35SV-12	1310#	77" X 12' Single Axle Vanguard
35SV-14	1535#	77" X 14' Single Axle Vanguard

OPTIONS

Electric Brakes On One Axle <i>(Includes complete break-a-way system w/charger)</i>
Spare Tire Mount (Side)
15" Spare Tire & Wheel
2" Bulldog Coupler
Fold-Up Jack
Set Back Jack
Removable Landscape Box — 24" X 24" X Width of Trailer