

PRO SERIES TANDEM AXLE EQUIPMENT TRAILER

G.V.W.R.	9,990#	AXLES	Two 5200# EZ LUBE w/ Electric Brakes
G.A.W.R. (EA. AXLE)	5,080#	SUSPENSION	Multi-Leaf Spring w/ Equalizer
COUPLER	2-5/16" Bulldog	TIRE	ST225/75-15 Load Range D
SAFETY CHAINS	1/4" Grd. 70 w/ Safety Latch Hook (2 ea.)	WHEEL	15 X 6 White Spoke 6 Bolt
JACK	2000# Top Wind (Bolted On)	FLOOR	2" Pine
TONGUE	5" Channel Fold-Back	LIGHTS	D.O.T. Stop, Tail, Turn and Clearance
TOP RAIL	(none)	ELEC. PLUG	7-Way RV
FRAME	5" Channel	FINISH (PREP)	Acid Etched w/White Phosphorus, Undercoated w/Panther 813 & Two Coats Primer
CROSSMEMBERS	3" Channel	FINISH	Painted w/ 2 Coats High Solid <i>Supreme</i> Acrylic Automotive Grade Enamel, and Pinstriped
UPRIGHTS	(none)		
FENDERS	9" X 72" Teardrop w/ Back		

STANDARD FEATURES

- Two 5200# Axles w/ Electric Brakes
- Complete Break-A-Way System w/ Charger
- 2-5/16" Bulldog Forged Coupler
- Lower Jack Support Plate
- Cambered Ez Lube Axles
- Spare Mount
- Safety Chains Attached w/ Cold Rolled Eyelets
- Floor Secured w/ 5/16" Torx Screws
- 2" Tubular Stop Rail
- Reflective Marker Tape
- 5' Stand-Up Ramps
- Tie Down Pockets – Sides, Front & Rear
- 32" Dovetail
- Square Front w/Diamond Plate
- Fold Back Tongue - 14' and Longer

10ET-16

DIMENSIONS			
LENGTH	A	B	C
16'	193-1/2"	78-1/2"	115"
18'	217-1/2"	90-1/2"	127"
20'	240"	102"	138"

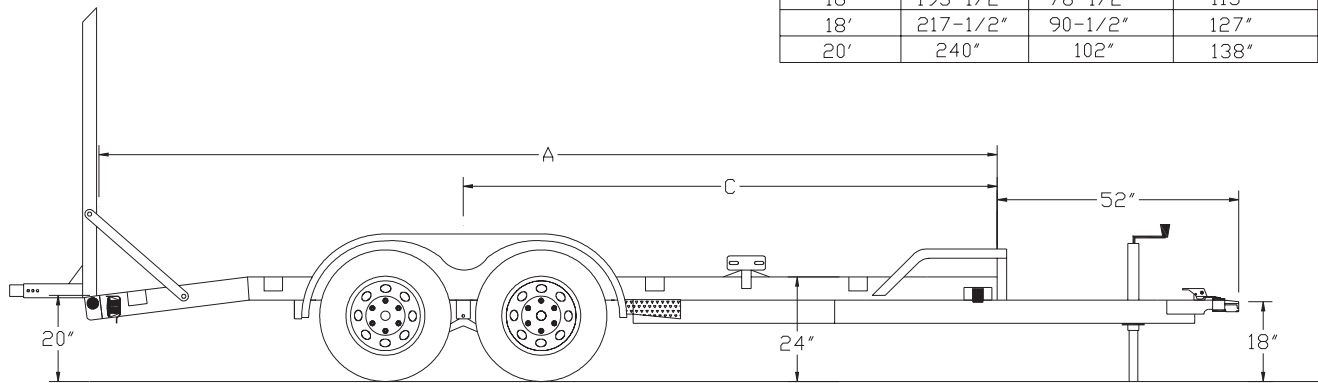

PRICING

MODEL #	WEIGHT	DESCRIPTION
10ET-16	2300#	83" X 16' Tandem Axle Equipment Trailer
10ET-18	2360#	83" X 18' Tandem Axle Equipment Trailer
10ET-20	2400#	83" X 20' Tandem Axle Equipment Trailer

OPTIONS

Hydraulic Brakes On 1 Axle w/ Adjustable Demco Actuator	
Hydraulic Brakes On 2 Axles w/ Adjustable Demco Actuator	
15" Spare Tire & Wheel – Load Range D	
7K Drop Leg Jack	
1/8" Diamond Plate Steel Floor (Per Sq. Ft.)	
Tire Upgrade to 16" – 7.50-16 LR-E	
Spare Upgrade to 16" – 7.50-16 LR-E	
Adjustable Coupler In Channel	