

SINGLE AXLE UTILITY TRAILER

G.V.W.R.	2,995#	AXLE	3500# EZ LUBE w/ Brake Flanges
G.A.W.R.	2,960#	SUSPENSION	Multi-Leaf Spring
COUPLER	2" A-Frame	TIRE	ST205/75-15 Load Range B
SAFETY CHAINS	1/4" Grd. 30 w/Safety Latch Hook (2 ea.)	WHEEL	15 x 5 White Spoke 5 Bolt
JACK	2000# Top Wind (Bolted On)	FLOOR	2" Pine
TONGUE	3" Channel Tongue	LIGHTS	D.O.T. Stop, Tail, Turn and Clearance
TOP RAIL	2-3/8" Pipe Square Back	ELEC. PLUG	4 Way Flat w/ Loom
FRAME	2" X 3" X 3/16" Angle	FINISH (PREP)	Acid Etched w/White Phosphorus, Undercoated w/Panther 813 & Two Coats Primer
CROSSMEMBERS	2" X 3" X 3/16" Angle	FINISH	Painted w/ 2 Coats High Solid <i>Supreme</i> Acrylic Automotive Grade Enamel, and Pinstriped
UPRIGHTS	15" Tall 2" X 2" X 1/8" Angle		
FENDERS	9" X 32" Rolled Formed w/ Back		

STANDARD FEATURES

- 3500# Idler Axle w/Flanges for Easy Brake Addition
- Top Rail Capped w/ Self Sealing Plugs
- Ez Lube Axle
- Bar & Pockets Across Back
- Lower Jack Support Plate
- 2-3/8" Pipe Top Rail
- Safety Chains Attached w/ Cold Rolled Eyelets
- Floor Secured w/ 5/16" Torx Screws

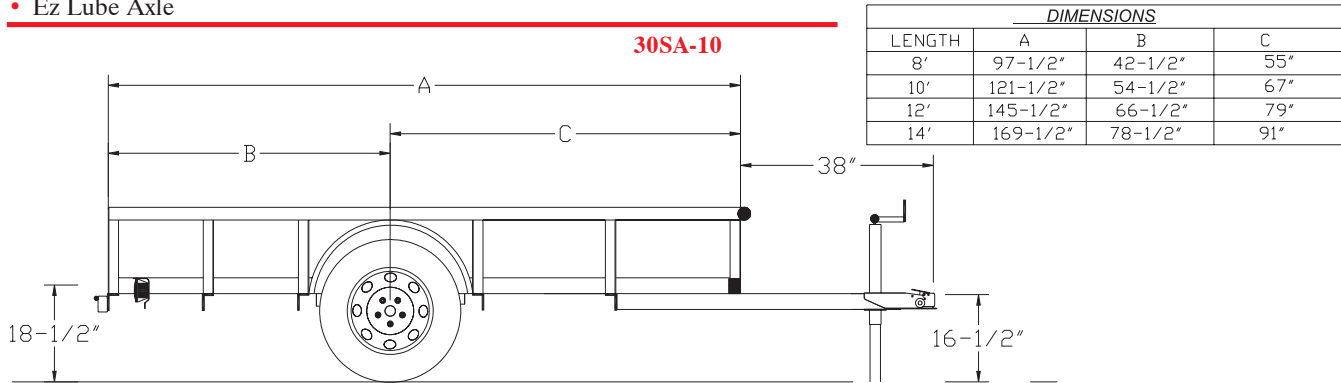

PRICING

MODEL #	WEIGHT	DESCRIPTION
30SA-8	680#	60" X 8' Single Axle
30SA-10	710#	60" X 10' Single Axle
30SA-12	740#	60" X 12' Single Axle
30SA-14	770#	60" X 14' Single Axle
35SA-10	850#	77" X 10' Single Axle
35SA-12	900#	77" X 12' Single Axle
35SA-14	950#	77" X 14' Single Axle

OPTIONS

Electric Brakes On One Axle (Includes complete break--a-way System)
Rampgate for 30SA / 4' Tall
Rampgate for 35SA / 4' Tall
Spare Tire Mount (Side)
15" Spare Tire & Wheel
2" Bulldog Coupler
2K Fold-Up Jack
Set Back Jack
Higher Side (Ea. Additional Foot)
Enclosed w/ Expanded Metal (Per Sq. Ft.)
Enclosed w/ Sheet Metal (Per Sq. Ft.) Change Toprail to 2" Sq. Tube
V-Tongue Tilt
Gas Spring Assist option for Rampgate
Car Hauler Style (Includes 6 Stake Pockets)
Tie Down Pockets (Ea.)