

# SINGLE AXLE LOW PROFILE DUMP

<b>G.V.W.R.</b>	5,000#	<b>AXLE</b>	5200# EZ LUBE w/ Elec. Brake
<b>G.A.W.R.</b>	5,080#	<b>SUSPENSION</b>	Multi-Leaf Spring
<b>COUPLER</b>	7K 2" Bulldog	<b>TIRE</b>	ST225/75-15 Load Range D
<b>SAFETY CHAINS</b>	¼" Grd. 70 w/ Safety Latch Hook (2 ea.)	<b>WHEEL</b>	15 X 6 White Spoke 6 Bolt
<b>JACK</b>	2000# Top Wind (Bolted On)	<b>FLOOR</b>	12 Ga. Smooth Steel
<b>TONGUE</b>	5" Channel	<b>LIGHTS</b>	D.O.T. Stop, Tail, Turn and Clearance
<b>FRAME</b>	5" Channel	<b>ELEC. PLUG</b>	7-Way RV
<b>CROSSMEMBERS</b>	3" X 3" Square Tubing	<b>FINISH (PREP)</b>	Acid Etched w/White Phosphorus, Undercoated w/Panther 813 & Two Coats Primer
<b>BED CROSSMEMBERS</b>	2" X 2" Square Tubing	<b>FINISH</b>	Painted w/ 2 Coats High Solid <i>Supreme</i> Acrylic Automotive Grade Enamel, and Pinstriped
<b>BED LONG SILS</b>	3" Channel		
<b>BED SIDE RAILS</b>	3" X 5" Formed Angle		
<b>FENDERS</b>	9" X 36" Radius' d		

## STANDARD FEATURES

- Complete Break-A-Way System w/ Charge Line
- 18" x 12 Ga. Sides w/Formed Supports
- 1 Piece 12 Ga. Floor
- Self Contained Electric / Hydraulic Scissor Lift
- Enclosed Pump & Battery Box Mounted In Front of Bed
- Lockable Control Unit
- Protected Lighting
- Cambered Ez Lube Axle
- 1 Piece 2 Way Style Rear Gate
- 1/2" Tie Rail On All 4 Sides
- 14 Stake Pockets (Sides & Front)
- 40 Degree Dump Angle

### 50DS-10

DIMENSIONS			
LENGTH	A	B	C
10'	120"	54"	66"

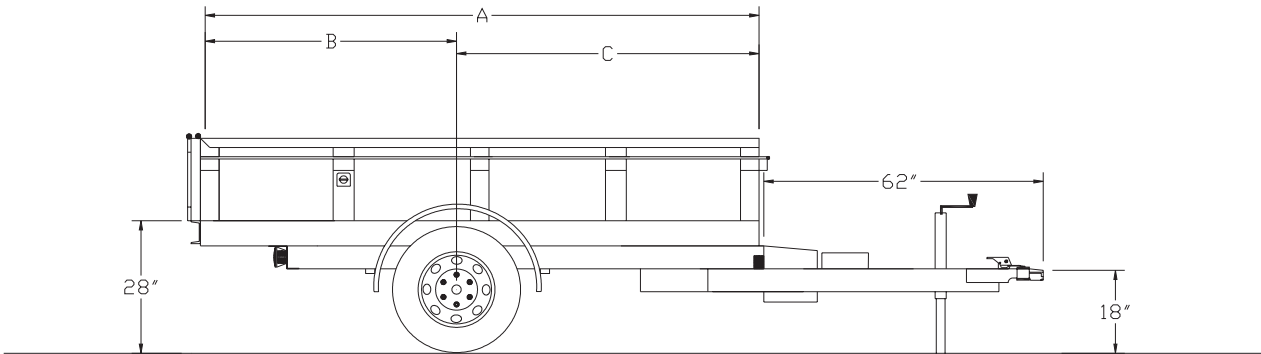

## TRAILER WEIGHTS & CAPACITIES

LENGTH	EMPTY WEIGHT	PAYLOAD	BOX CAPACITY
10'	1,850#	3,150#	2.5 Cubic Yards

## PRICING

MODEL #	DESCRIPTION
50DS-10	53" X 10' Low Profile Single Axle Dump

## OPTIONS

Hydraulic Brakes on 1 Axle w/ Toledo Actuator	
Double Rear Gate	
15" Spare Tire & Wheel	
Spare Tire Mount (Side)	
Adjustable Coupler In Channel	

Prices Effective January 1, 2005

© 2005 Copyright by Big Tex Trailer Manufacturing, Inc.