

# 15LT

## LIL TEX UTILITY TRAILER

<b>G.V.W.R.</b> 1,500#	<b>AXLE</b> 2000# EZ LUBE
<b>G.A.W.R.</b> 1,560#	<b>SUSPENSION</b> Multi-Leaf Slipper Spring
<b>COUPLER</b> 2" Coupler	<b>TIRE</b> 4.80-12" Load Range B
<b>SAFETY CHAINS</b> ¼" Grd. 30 w/Safety Latch Hook (2 ea.)	<b>WHEEL</b> 12 x 4 White Spoke 5 Bolt
<b>JACK</b> (none)	<b>FLOOR</b> 2" Pine
<b>TONGUE</b> Single 2" X 3" Tubing	<b>LIGHTS</b> D.O.T. Stop, Tail, Turn and Clearance
<b>TOP RAIL</b> 1" X 2" Tubing	<b>ELEC. PLUG</b> 4 Way Flat w/ Loom
<b>FRAME</b> 2" X 2" Angle	<b>FINISH (PREP)</b> Acid Etched w/White Phosphorus, Undercoated w/Panther 813 & Two Coats Primer
<b>CROSSMEMBERS</b> 2" X 2" Angle	<b>FINISH</b> Painted w/ 2 Coats High Solid <i>Supreme</i> Acrylic Automotive Grade Enamel, and Pinstriped
<b>UPRIGHTS</b> 10" Tall 1" X 2" Tubing	
<b>FENDERS</b> 7" X 28" Rolled Formed w/Backs	

### STANDARD FEATURES

- Floor Secured w/ 5/16" Torx Screws
- 4 each Tiedowns
- Ez Lube Axle
- Safety Chains Attached w/ Cold Rolled Eyelets
- Radius 1-PC Tubular Top Rail
- Tubular Raised Tongue
- Lower Tongue Support & Handle

**15LT-8**

DIMENSIONS			
LENGTH	A	B	C
8'	97-1/2"	44-1/2"	53"

Shown with optional gate.

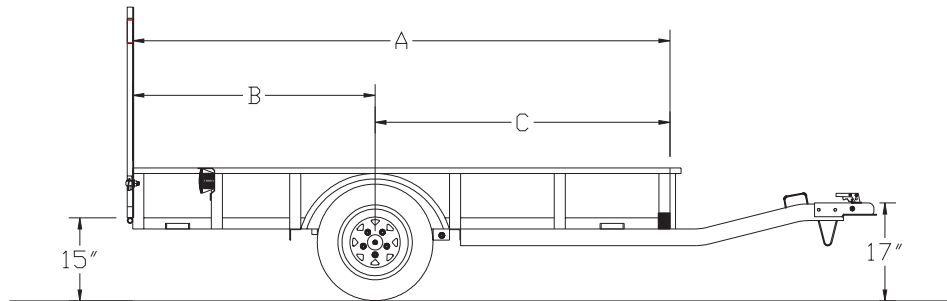

*( Only Available This Length )*

### PRICING

MODEL #	WEIGHT	DESCRIPTION	
15LT-8	430#	50" X 8' Single Axle	

### OPTIONS

3' Tubular Rampgate w/Exp. Mtl.	
---------------------------------	--