

SUPER LIL TEX UTILITY TRAILER

G.V.W.R.	1,995#	AXLE	2000# EZ LUBE
G.A.W.R.	2,000#	SUSPENSION	Multi-Leaf Spring
COUPLER	2" A-Frame	TIRE	ST175/80 – 13" Load Range B
SAFETY CHAINS	1/4" Grd. 30 w/Safety Latch Hook (2 ea.)	WHEEL	13 x 4.5 White Spoke 5 Bolt
JACK	2000# Top Wind (Bolted On)	FLOOR	2" Pine
TONGUE	3" Channel – V-Tongue	LIGHTS	D.O.T. Stop, Tail, Turn and Clearance
TOP RAIL	2" X 2" X 1/8" Angle	ELEC. PLUG	4 Way Flat w/ Loom
FRAME	3" X 2" X 3/16" Angle	FINISH (PREP)	Acid Etched w/White Phosphorus, Undercoated w/Panther 813 & Two Coats Primer
CROSSMEMBERS	2" X 2" X 1/8" Angle	FINISH	Painted w/ 2 Coats High Solid <i>Supreme</i> Acrylic Automotive Grade Enamel, and Pinstriped
UPRIGHTS	11" Tall 2" X 2" X 1/8" Angle		
FENDERS	9" X 32" Square w/ Backs		

STANDARD FEATURES

- Floor Secured w/ 5/16" Torx Screws
- Flared Top Rail in Front for Extra Space
- Ez Lube Axle
- Safety Chains Attached w/ Cold Rolled Eyelets
- Lower Jack Support Plate
- 4 Tie Downs

19SL-9

DIMENSIONS			
LENGTH	A	B	C
9'	109-1/2"	41-3/4"	67-3/4"

(Shown with Optional Rampgate)

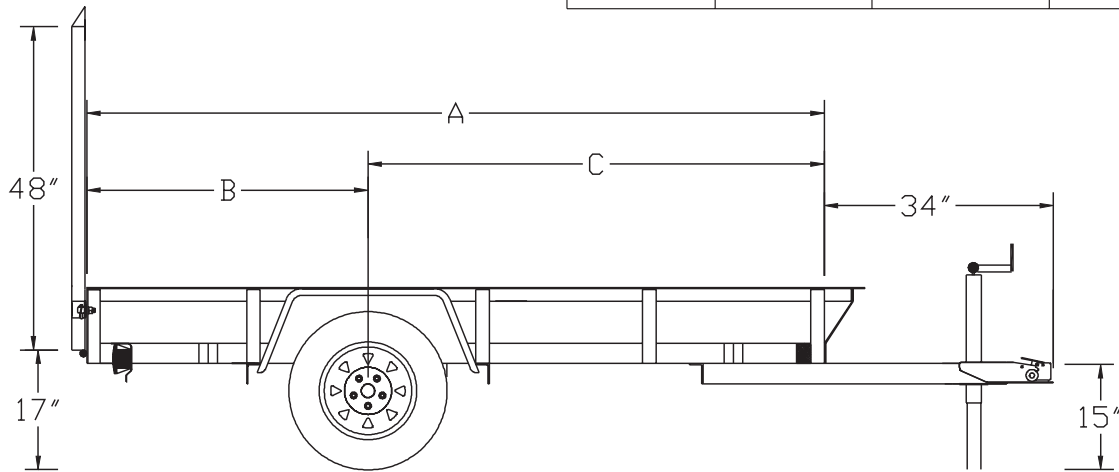

PRICING

MODEL #	WEIGHT	DESCRIPTION
19SL-9	460#	54" X 9' Single Axle Trailer

OPTIONS

2" Tubular Rampgate for 19SL — 4' Tall
--