

HINO 268

4 x 2 CONVENTIONAL

GVW: 25,950 lbs.

BBC: 108"

ENGINE MODEL: J08E-TV (Turbo Intercooled)

DIMENSIONS (On standard specification)

Wheelbase/code	A in.	152.0/G	175.0/J	187.0/L	205.0/M	217.0/P	235.0/R	253.0/T	271.0/V
Overall length	B in.	242.6	278.6	302.6	320.6	354.6	372.6	390.6	390.6
Overall width	C in.	96.3	96.3	96.3	96.3	96.3	96.3	96.3	96.3
Overall height	D in.	106.7	106.7	106.7	106.7	106.7	106.7	106.7	106.7
Cab to axle	E in.	84.6	107.6	119.6	137.6	149.6	167.6	185.6	203.6
Rear overhang	F in.	50.0	63.0	75.0	75.0	97.0	97.0	97.0	79.0
Frame height at:									
Front axle	G in.	36.8	36.8	36.8	36.8	36.8	36.8	36.8	36.8
Rear axle	H in.	39.8	39.8	39.8	39.8	39.8	39.8	39.8	39.8
Road clearance (at diff. axle)	J in.	11.2	11.2	11.2	11.2	11.2	11.2	11.2	11.2
Tread:									
Front	K in.	78.0	78.0	78.0	78.0	78.0	78.0	78.0	78.0
Rear	L in.	72.0	72.0	72.0	72.0	72.0	72.0	72.0	72.0
Turning radius:									
Tire	ft.	42.2	47.8	50.8	55.2	58.2	62.6	67.0	71.4
Wall to wall	ft.	45.8	51.4	54.2	58.6	61.6	66.0	70.4	74.8

CHASSIS WEIGHTS (On standard specification)

MT	Total weight lb.	9,500	9,470	9,530	9,650	9,760	9,820	9,870	9,910
	Front axle lb.	5,985	6,010	6,060	6,165	6,190	6,250	6,310	6,365
	Rear axle lb.	3,515	3,460	3,470	3,485	3,570	3,570	3,560	3,515
AT	Total weight lb.	9,450	9,400	9,470	9,580	9,690	9,770	9,800	9,840
	Front axle lb.	5,910	5,915	5,975	6,075	6,095	6,175	6,230	6,315
	Rear axle lb.	3,540	3,485	3,495	3,505	3,595	3,595	3,570	3,525

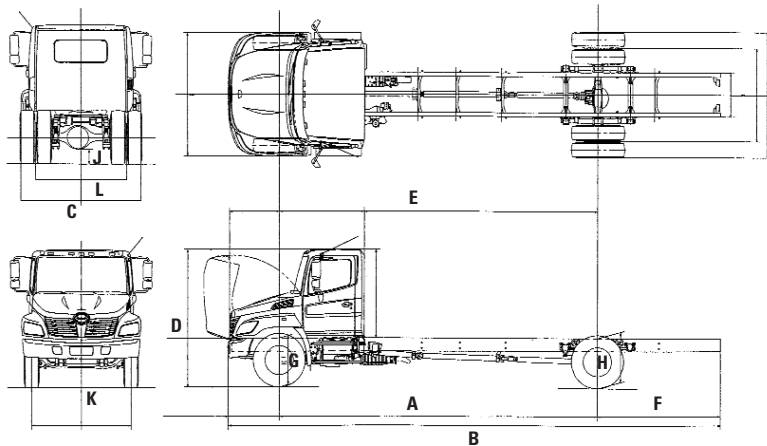

ENGINE

MODEL	HINO J08E-TV
Type	Diesel 4-cycle, 6-cylinder in-line, water-cooled
Combustion system	Direct injection type
Max. output (SAE Gross)	220 hp at 2,500 rpm
Max. torque (SAE Gross)	520 lb.-ft. at 1,500 rpm
Bore and stroke	4.41 x 5.12 in.
Piston displacement	7.680 L
Fuel injection pump	Radial plunger (HP-4)
Governor	Electronically controlled
Intake system	Turbocharged and intercooled
Air cleaner	Paper filter type (DONALDSON)
Fan clutch	Bimetal thermostat sensor regulates fan speed
Glow plugs	Standard
Air compressor	Single cylinder, 6.8 cfm @ 1,250

POWERTRAIN & PERFORMANCE

25,950 lbs. GVW				
Powertrain	<input type="checkbox"/> STD.	<input type="checkbox"/> OPT.	<input type="checkbox"/> OPT.	<input type="checkbox"/> OPT.
Max. speed mph	75	76	78	79
Startability (tan.θ) %	44.2	42.6	34.3	33.7
Transmission	Model	Eaton FS5406A	Allison 2200 RDS	
	Type	Six-speed direct drive synchromesh 1st-6th	Five-speed automatic RDS	
	1st.	9.008	3.102	
	2nd.	5.270	1.811	
	3rd.	3.220	1.406	
Ratios	4th.	2.040	1.000	
	5th.	1.361	0.712	
	6th.	1.000	—	
	Rev.	8.625	4.492	
Rear axle gear ratios	4.110	3.730	5.570	5.130
Tire is combined with ratio	11R22.5-14	255/80R22.5	11R22.5-14	255/80R22.5



HINO 268

4 x 2 CONVENTIONAL

GVW: 25,950 lbs. BBC: 108"

ENGINE MODEL: J08E-TV (Turbo Intercooled)

WEIGHT CAPACITIES

Front axle	lbs.	10,000
Rear axle	lbs.	19,000
Front spring	lbs.	12,000
Rear spring	lbs.	19,000

LIQUID CAPACITIES

Fuel tank	gal./US	52
Cooling system	gal./US	6.21 : Eaton FS5406A
	gal./US	6.08 : ALLISON 2200
Engine oil	qt./US	16.15

AXLE / SUSPENSION

Front axle	MFS-10 series reversed Elliot, "I" beam, oil-lubricated
Front spring	Taper-leaf springs w/shock absorbers
Rear axle	RS19-145 series Full-floating, single reduction Single-speed by hypoid gearings
Rear spring	Semi-elliptic main and auxiliary helper-leaf spring

FRAME

Ladder type		Straight C Channel
Width	in.	34
Yield strength	PSI	80,000
Resisting bending moment (one side)	in-lbs.	1,031,900 no reinforcement

STEERING

Type	TRW-TAS65 recirculating ball with tilt and telescopic steering column.
------	--

CLUTCH

Type	Twin plate with damper springs EATON-SPICER SAS1401 series
Facing material	Cerametallic
Facing outside diameter in.	13.8
Control	Hydraulic

WHEELS / TIRES

6 Wheels	22.5 x 8.25 10-stud disc.
6 Tires	11R22.5 (G)
Pattern	Front rib / Rear lug

BRAKES

Service brake	Hydraulic system with disc brake for front and rear wheels, with automatic adjustment
Disc diameter x pad area x thickness in.	Front: 15.375 x 18.96 x 0.74
	Rear: 15.375 x 18.96 x 0.74
Control	Hydraulic dual circuit with Antilock Brake System (ABS)
Parking brake	Mechanical, internal expanding acting on transmission output shaft
Drum diameter in.	12 : MERITOR (auto) 9 : BOSCH (manual)

CAB EQUIPMENT

Cab construction	All steel welded
Seating	Three-person
Driver's seat	Adjustable reclining, vinyl with coil suspension
Passenger's seat	Bench type, vinyl (Two passenger)
Seat belts	3-point type (driver and passenger), one 2-point type (center)
A/C	134 Denso
Heater/Defroster	18,357 BTU/h
Mirrors outside rearview	Four; one flat and one convex at each side
Sun visors	Two – flip-down
Overhead compartment	Two with latching doors
Chrome grille	Standard
Windshield	Laminated
Windshield wipers	Dual electric, 2-speed and intermittent
Cup holders	Standard
Cigarette lighter	Standard
Coat hook	One (rear panel)
Door pockets	Two
Cruise control	Standard

DASH INSTRUMENTATION

Meters and gauges	
Speedometer-mph (km/h)	
Odometer (mile)	
Fuel gauge	
Coolant temperature gauge	
Engine tachometer	
Warning lamps and buzzers	
Oil pressure warning lamp and buzzer	
Brake pressure warning lamp and buzzer	
Coolant level warning lamp and buzzer	
Battery charging system warning lamp	
High beam indicator lamp	
Turn signal indicator	
Parking brake warning lamp	
Engine control system warning lamp	
ABS warning lamp	
Driver Information Display	
Instant & trip fuel consumption	
DPR monitor	
Maintenance schedules	
Engine/vehicle diagnostics	

ELECTRICAL EQUIPMENT

Batteries	Two, parallel connection, each 12 V
Capacity	1200 CCA
Alternator	12 V, 100 A, brush Delco
Starter	12 V 2.5kw Denso
Audio	AM/FM radio with CD, two speaker
Headlamps	Integrated with turn signal and hazard lamps
Stop/Tail lamps	
Back-up lamps	
Side-flasher lamp	
Trucklite LED cab marker lamps	
Electric horn (dual)	

CHASSIS EQUIPMENT

Fuel pre-filter	Davco 230 FuelPro® Heated fuel/water separator
Reflectors	Two rear, two front side
Tow hook	One at front
Air dryer	NABCO, heated
Air tank	49 L

OPTIONS

Cloth seats
Single passenger's seat – Adjustable reclining
Rear shock absorbers
Clutch (Dry single plate with auto adjuster SAS 1401 Solo)
Clutch (Dry twin plate with auto adjuster SAS 1402 Solo)
Cold weather package (includes)
Heated mirror
Block heater
Front Bumper (Three pieces)
Front Bumper (Three pieces with 4 inch extension/black)
Front Bumper (4 inch extension/black)
Front Bumper (chrome)
Front Bumper (4 inch extension/chrome)
Alternator – 12 V, 105 A, brushless
Power Windows
Battery – 12 V GR31 x 2; GR31 x 3; GR27 x 3
Tire size – 255/80R22.5-14 (G)
Tire size – 255/70R22.5-16 (H)
Fuel tank – dual 52 gal./US; 95 gal./US
Tires – Front: rib, Rear: rib
Auto. trans.: 2200HS
Exhaust system – Stack tail type; vertical stack
Chrome mirrors – heated/non-heated
Synthetic fluids – transmission/rear differential
Cab paint – red or black
Safety kit (fire extinguisher and triangle kit)
Rear stabilizer
Aluminum Wheels
Exhaust brake – Electric-pneumatic with valve in exhaust pipe

ROADSIDE ASSISTANCE

HinoWatch (service free of charge)	3-year unlimited roadside assistance <ul style="list-style-type: none"> • Lockout • Out of Fuel • Battery Jumpstart • Information • Warranty Towing
------------------------------------	--

NOTE:

All specifications of the products are with normal manufacturing allowances and tolerances. HINO MOTORS SALES U.S.A., INC. reserves the right to alter specifications at any time without previous notice. Some optional items may require extra lead time.