

HINO 268A

4 x 2 CONVENTIONAL

GVW: 25,950 lbs.

BBC: 108"

ENGINE MODEL: J08E-TV (Turbo Intercooled)

DIMENSIONS (On standard specification)

Wheelbase/code	A in.	152.0/G	175.0/J	187.0/L	205.0/M	217.0/P	235.0/R	253.0/T	271.0/V
Overall length	B in.	242.6	278.6	302.6	320.6	354.6	372.6	390.6	390.6
Overall width	C in.	96.5	96.5	96.5	96.5	96.5	96.5	96.5	96.5
Overall height	D in.	106.7	106.7	106.7	106.7	106.7	106.7	106.7	106.7
Cab to axle	E in.	84.6	107.6	119.6	137.6	149.6	167.6	185.6	203.6
Rear overhang	F in.	50.0	63.0	75.0	75.0	97.0	97.0	97.0	79.0
Frame height at:									
Front axle	G in.	37.0	37.0	37.0	37.0	37.0	37.0	37.0	37.0
Rear axle	H in.	39.8	39.8	39.8	39.8	39.8	39.8	39.8	39.8
Road clearance (at diff. axle)	J in.	11.2	11.2	11.2	11.2	11.2	11.2	11.2	11.2
Tread:									
Front	K in.	79.3	79.3	79.3	79.3	79.3	79.3	79.3	79.3
Rear	L in.	72.2	72.2	72.2	72.2	72.2	72.2	72.2	72.2
Turning radius:									
Tire	ft.	57.6	62.0	66.4	70.8	57.6	62.0	66.4	70.8
Wall to wall	ft.	61.0	65.4	69.8	74.2	61.0	65.4	69.8	74.2

CHASSIS WEIGHTS (On standard specification)

MT	Total weight	lb.	9,900	9,870	9,930	10,040	10,150	10,220	10,260	10,310
	Front axle	lb.	6,085	6,120	6,160	6,260	6,280	6,350	6,415	6,505
	Rear axle	lb.	3,815	3,750	3,770	3,780	3,870	3,870	3,845	3,805
AT	Total weight	lb.	9,850	9,810	9,880	9,990	10,100	10,170	10,210	10,250
	Front axle	lb.	6,035	6,050	6,110	6,210	6,230	6,300	6,365	6,445
	Rear axle	lb.	3,815	3,760	3,770	3,780	3,870	3,870	3,845	3,805

ENGINE

MODEL	HINO J08E-TV
Type	Diesel 4-cycle, 6-cylinder in-line, water-cooled
Combustion system	Direct injection type
Max. output (SAE Gross)	220 hp at 2,500 rpm
Max. torque (SAE Gross)	520 lb.-ft. at 1,500 rpm
Bore and stroke	4.41 x 5.12 in.
Piston displacement	7.680 L
Fuel injection pump	Radial plunger (HP-4)
Governor	Electronically controlled
Intake system	Turbocharged and intercooled
Air cleaner	Paper filter type (DONALDSON)
Fan clutch	Bimetal thermostat sensor regulates fan speed
Glow plugs	Standard
Air compressor	Single cylinder, 10.0 cfm @ 1,250 rpm

POWERTRAIN & PERFORMANCE

25,950 lbs. GVW					
Powertrain		<input type="checkbox"/> STD.	<input type="checkbox"/> OPT.	<input type="checkbox"/> OPT.	<input type="checkbox"/> OPT.
Max. speed	mph	75	78	78	79
Startability (tan.θ) %		44.2	42.6	34.3	33.7
Transmission	Model	Eaton FS5406A	Allison 2200 HS/RDS		
	Type	Six-speed direct drive synchromesh 1st-6th	Five-speed automatic		
Ratios	1st.	9.008	3.102		
	2nd.	5.270	1.811		
	3rd.	3.220	1.406		
	4th.	2.040	1.000		
	5th.	1.361	0.712		
	6th.	1.000	—		
	Rev.	8.625	4.492		
Rear axle gear ratios		4.110	3.730	5.570	5.130
Tire is combined with ratio		11R22.5-14	255/80R22.5	11R22.5-14	255/80R22.5

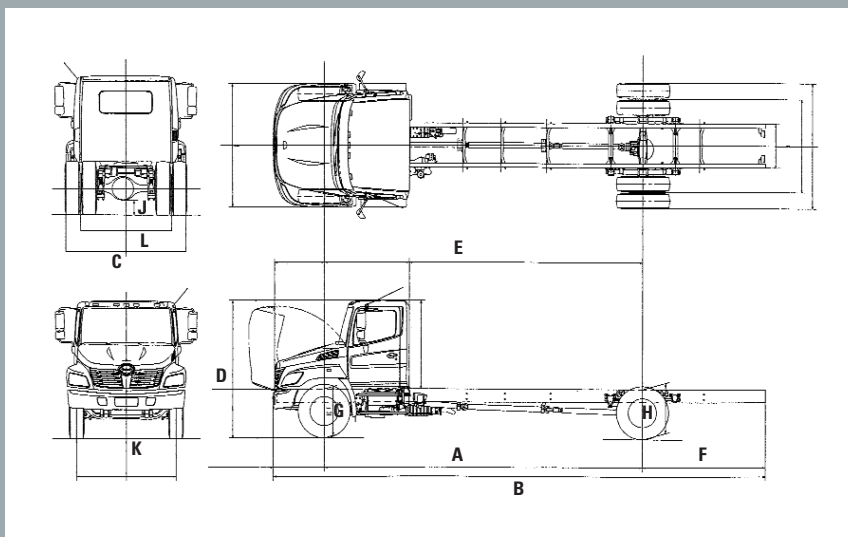

HINO 268A

4 x 2 CONVENTIONAL

GVW: 25,950 lbs. BBC: 108"

ENGINE MODEL: J08E-TV (Turbo Intercooled)

WEIGHT CAPACITIES

Front axle	lbs.	10,000
Rear axle	lbs.	19,000
Front spring	lbs.	12,000
Rear spring	lbs.	19,000

LIQUID CAPACITIES

Fuel tank	gal./US	52
Cooling system	6.21	: Eaton FS5406A
	gal./US	6.08 : ALLISON 2200
Engine oil	qt./US	16.15

AXLE / SUSPENSION

Front axle	MFS-10 series reversed Elliot, "I" beam, oil-lubricated
Front spring	Taper-leaf springs w/shock absorbers
Rear axle	RS19-145 series Full-floating, single reduction, single-speed by hypoid gears, with oil-lubricated type
Rear spring	Semi-elliptic main and auxiliary helper-leaf spring

FRAME

Ladder type		Straight C Channel
Width	in.	34
Yield strength	PSI	80,000
Resisting bending moment (one side)	in.-lbs.	1,031,900 no reinforcement

STEERING

Type	TRW-TAS65 recirculating ball with tilt and telescopic steering column
------	---

CLUTCH

Type	Dry single plate with damper springs EATON-SPICER SAS1401 series
Facing material	Cermetallic
Facing outside diameter in.	13.8
Control	Hydraulic

WHEELS / TIRES

Wheels	22.5 x 8.25 10-stud disc.
Tires	11R22.5 (G)
Pattern	Front rib / Rear lug

BRAKES

Service brake	Full air, dual circuit, "S" cam type, leading & trailing shoes, with automatic adjustment
Drum diameter x lining width x thickness in.	Front: 15 x 4 x 0.73
	Rear: 16.5 x 7 x 0.85
Control	Full air dual circuit with Antilock Brake System (ABS)
Parking brake	Spring brake acting on rear wheels

CAB EQUIPMENT

Cab construction	All steel welded
Seating	Three-person
Driver's seat	Adjustable reclining, vinyl with coil air suspension
Passenger's seat	Bench type, vinyl (Two passenger)
Seat belts	3-point type (driver and passenger), one 2-point type (center)
A/C	134 Denso
Heater/Defroster	18,357 BTU/h
Mirrors outside rearview	Four; one flat and one convex at each side
Sun visors	Two – flip-down
Overhead compartment	Two with latching doors
Chrome grille	Standard
Windshield	Laminated
Windshield wipers	Dual electric, 2-speed and intermittent
Cup holders	Standard
Cigarette lighter	Standard
Coat hook	One (rear panel)
Door pockets	Two
Cruise control	Standard

DASH INSTRUMENTATION

Meters and gauges	
Speedometer-mph (km/h)	
Odometer (mile)	
Fuel gauge	
Coolant temperature gauge	
Engine tachometer	
Air pressure gauge	
Warning lamps and buzzers	
Oil pressure warning lamp and buzzer	
Brake pressure warning lamp and buzzer	
Coolant level warning lamp and buzzer	
Battery charging system warning lamp	
High beam indicator lamp	
Turn signal indicator	
Parking brake warning lamp	
Engine control system warning lamp	
ABS warning lamp	
Driver Information Display	
Instant & trip fuel consumption	
DPR monitor	
Maintenance schedules	
Engine/vehicle diagnostics	

ELECTRICAL EQUIPMENT

Batteries	Two, parallel connection, each 12 V
Capacity	1200 CCA
Alternator	12 V, 100 A, brush Delco
Starter	12 V 2.5kw Denso
Audio	AM/FM radio with CD, Two speaker
Headlamps	Integrated with turn signal and hazard lamps

Stop/Tail lamps
Back-up lamps
Side-flasher lamp
Trucklite LED cab marker lamps
Electric horn (dual)

CHASSIS EQUIPMENT

Fuel pre-filter	Davco 230 FuelPro® Heated fuel/water separator
Tow hook	One at front
Air dryer	Heated, standard
Air tank	68 L

OPTIONS

Cloth seats
Single passenger's seat – Adjustable reclining
Rear shock absorbers
Clutch (Dry single plate with auto adjuster SAS 1401 Solo)
Clutch (Dry twin plate with auto adjuster SAS 1402 Solo)
Cold weather package (includes)
Heated mirrors
Block heater
Heated Air Dryer (Bendix)
Front Bumper (Three pieces)
Front Bumper (Three pieces with 4 inch extension/black)
Front Bumper (4 inch extension / black)
Front Bumper (chrome)
Front Bumper (4 inch extension/chrome)
Alternator – 12 V, 105 A, brushless
Battery – 12 V GR31 x2; GR31 x 3; GR27 x 3
Tire size – 255/80R22.5-14 (G)
Tire size – 255/70R22.5-16 (H)
Fuel tank – dual 52 gal./US; 95 gal./US
Tires – Front: rib, Rear: rib
Air horn
Auto. trans.: 2200 HS (no PTO provision)
Auto. trans.: 2200 RDS (with PTO provision)
Exhaust system – Stack tail type; vertical stack
Chrome mirrors – heated/non-heated
Hendrickson air suspension
Electric central dump valve
Synthetic fluids – transmission/rear differential
Cab paint – red; black
Safety kit (fire extinguisher and triangle kit)
Rear stabilizer
Power windows
Aluminum wheels
Exhaust brake – Electric-pneumatic with valve in exhaust pipe

ROADSIDE ASSISTANCE

HinoWatch (service free of charge)	3-year unlimited roadside assistance • Lockout • Out of Fuel • Battery Jumpstart • Information • Warranty Towing
------------------------------------	---

NOTE:

All specifications of the products are with normal manufacturing allowances and tolerances. HINO MOTORS SALES U.S.A., INC. reserves the right to alter specifications at any time without previous notice. Some optional items may require extra lead time.