

HINO 338

4 x 2 CONVENTIONAL

GVW: 33,000 lbs.

BBC: 108"

ENGINE MODEL: J08E-TW (Turbo Intercooled)

DIMENSIONS (On standard specification)

| Wheelbase/code | A in. | 152.0/G | 175.0/J | 187.0/L | 205.0/M | 217.0/P | 235.0/R | 253.0/T | 271.0/V |
|--------------------------------|-------|---------|---------|---------|---------|---------|---------|---------|---------|
| Overall length | B in. | 242.6 | 278.6 | 302.6 | 320.6 | 354.6 | 372.6 | 390.6 | 390.6 |
| Overall width | C in. | 96.5 | 96.5 | 96.5 | 96.5 | 96.5 | 96.5 | 96.5 | 96.5 |
| Overall height | D in. | 106.9 | 106.9 | 106.9 | 106.9 | 106.9 | 106.9 | 106.9 | 106.9 |
| Cab to axle | E in. | 84.6 | 107.6 | 119.6 | 137.6 | 149.6 | 167.6 | 185.6 | 203.6 |
| Rear overhang | F in. | 50.0 | 63.0 | 75.0 | 75.0 | 97.0 | 97.0 | 97.0 | 79.0 |
| Frame height at: | | | | | | | | | |
| Front axle | G in. | 36.8 | 36.8 | 36.8 | 36.8 | 36.8 | 36.8 | 36.8 | 36.8 |
| Rear axle | H in. | 40.6 | 40.6 | 40.6 | 40.6 | 40.6 | 40.6 | 40.6 | 40.6 |
| Road clearance (at diff. axle) | J in. | 11.2 | 11.2 | 11.2 | 11.2 | 11.2 | 11.2 | 11.2 | 11.2 |
| Tread: | | | | | | | | | |
| Front | K in. | 79.3 | 79.3 | 79.3 | 79.3 | 79.3 | 79.3 | 79.3 | 79.3 |
| Rear | L in. | 72.2 | 72.2 | 72.2 | 72.2 | 72.2 | 72.2 | 72.2 | 72.2 |
| Turning radius: | | | | | | | | | |
| Tire | ft. | 42.0 | 47.5 | 50.4 | 54.8 | 57.7 | 62.1 | 66.4 | 70.8 |
| Wall to wall | ft. | 45.4 | 50.9 | 53.8 | 58.2 | 61.1 | 65.5 | 69.8 | 74.2 |

CHASSIS WEIGHTS (On standard specification)

| | Total weight lb. | 10,060 | 10,190 | 10,260 | 10,380 | 10,520 | 10,620 | 10,660 | 10,710 |
|-----------|------------------|--------|--------|--------|--------|--------|--------|--------|--------|
| MT | Front axle lb. | 6,170 | 6,275 | 6,315 | 6,410 | 6,440 | 6,540 | 6,595 | 6,700 |
| | Rear axle lb. | 3,890 | 3,915 | 3,945 | 3,970 | 4,080 | 4,080 | 4,065 | 4,010 |
| | Total weight lb. | 10,300 | 10,420 | 10,490 | 10,620 | 10,750 | 10,850 | 10,890 | 10,950 |
| AT | Front axle lb. | 6,345 | 6,440 | 6,490 | 6,610 | 6,625 | 6,725 | 6,780 | 6,895 |
| | Rear axle lb. | 3,955 | 3,980 | 4,000 | 4,010 | 4,125 | 4,125 | 4,110 | 4,055 |

ENGINE

| MODEL | HINO J08E-TW |
|-------------------------|--------------------------------------------------|
| Type | Diesel 4-cycle, 6-cylinder in-line, water-cooled |
| Combustion system | Direct injection type |
| Max. output (SAE Gross) | 260 hp at 2,500 rpm |
| Max. torque (SAE Gross) | 585 lb.-ft. at 1,500 rpm |
| Bore and stroke | 4.41 x 5.12 in. |
| Piston displacement | 7.680 L |
| Fuel injection pump | Radial plunger (HP-4) |
| Governor | Electronically controlled |
| Intake system | Turbocharged and intercooled |
| Air cleaner | Paper filter type (DONALDSON) |
| Air compressor | Single cylinder, water-cooled |
| Fan clutch | Bimetal thermostat sensor regulates fan speed |
| Glow plugs | Standard |
| Air compressor | Single cylinder, 10.0 cfm @ 1,250 rpm |

POWERTRAIN & PERFORMANCE

| 33,000 lbs. GVW | | | | |
|-----------------------------|--------------------------------------------|-------------------------------|-------------------------------|------------------------------|
| Power line | <input type="checkbox"/> STD. | <input type="checkbox"/> OPT. | <input type="checkbox"/> OPT. | <input type="checkbox"/> OPT |
| Max. speed mph | 75 | 77 | 74 | 76 |
| Startability (tan.θ) % | 38.2 | 37.2 | 49.3 | 48.0 |
| Transmission Model | Eaton FS6406A | | Allison 3000RDS | |
| Type | Six-speed direct drive synchromesh 1st-6th | | Five-speed automatic | |
| 1st. | 9.008 | | 3.487 | |
| 2nd. | 5.270 | | 1.864 | |
| 3rd. | 3.220 | | 1.409 | |
| Ratios | 4th. 2.040 | | 1.000 | |
| 5th. | 1.361 | | 0.750 | |
| 6th. | 1.000 | | — | |
| Rev. | 8.625 | | 5.027 | |
| Rear axle gear ratios | 4.110 | 3.900 | 5.570 | 5.290 |
| Tire is combined with ratio | 11R22.5-14 | 295/75R22.5 | 11R22.5-14 | 295/75R22.5 |

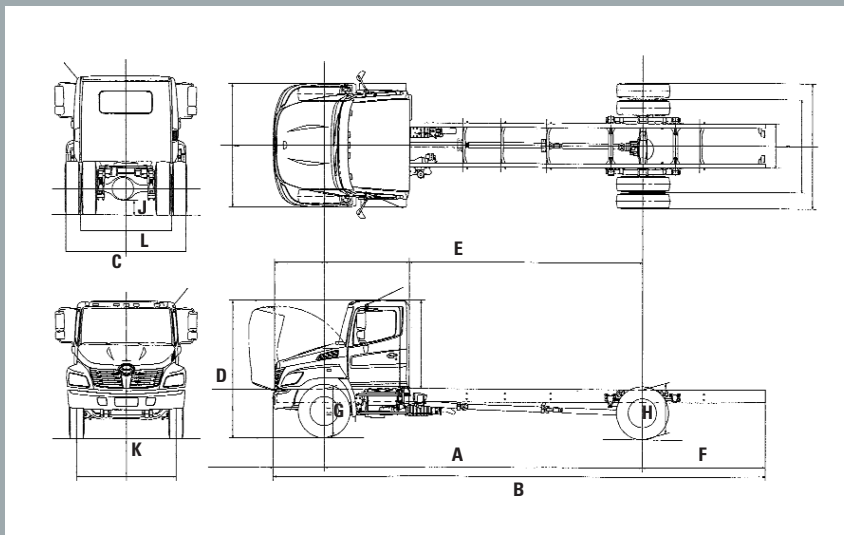

HINO 338

4 x 2 CONVENTIONAL

GVW: 33,000 lbs. BBC: 108"

ENGINE MODEL: J08E-TW (Turbo Intercooled)

SPEC NO. SS-NV024

WEIGHT CAPACITIES

| | | |
|--------------|------|--------|
| Front axle | lbs. | 12,000 |
| Rear axle | lbs. | 21,000 |
| Front spring | lbs. | 12,000 |
| Rear spring | lbs. | 21,000 |

LIQUID CAPACITIES

| | | |
|----------------|---------|------------------------------------------------|
| Fuel tank | gal./US | 52 |
| Cooling system | gal./US | 6.21 : Eaton FS6406A 6.08 : ALLISON 3000RDS |
| Engine oil | qt./US | 16.15 |

AXLE / SUSPENSION

| | |
|--------------|---------------------------------------------------------------------------------|
| Front axle | MFS-12 series reversed Elliot, "I" beam, oil-lubricated |
| Front spring | Taper-leaf springs w/shock absorbers |
| Rear axle | RS21-145 series Full-floating, single reduction Single-speed by hypoid gearings |
| Rear spring | Semi-elliptic main and auxiliary helper-leaf spring |

FRAME

| | | |
|-------------------------------------|--------------------|----------------------------------|
| Ladder type | Straight C Channel | |
| Width | in. | 34: W/B=175-235 34.1: W/B=253 |
| Yield strength | PSI | 80,000 |
| Resisting bending moment (one side) | in.-lbs. | 1,280,800 no reinforcement |

STEERING

| | |
|------|-----------------------------------------------------------------------|
| Type | TRW-TAS65 recirculating ball with tilt and telescopic steering column |
|------|-----------------------------------------------------------------------|

CLUTCH

| | |
|-----------------------------|------------------------------------------------------------------|
| Type | Dry single plate with damper springs EATON-SPICER SAS1401 series |
| Facing material | Cerametallic |
| Facing outside diameter in. | 13.8 |
| Control | Hydraulic |

WHEELS / TIRES

| | |
|----------|---------------------------|
| 6 Wheels | 22.5 x 8.25 10-stud disc. |
| 6 Tires | 11R22.5-14 (G) |
| Pattern | Front rib / Rear lug |

BRAKES

| | |
|----------------------------------------------|-------------------------------------------------------------------------------------------|
| Service brake | Full air, dual circuit, "S" cam type, leading & trailing shoes, with automatic adjustment |
| Drum diameter x lining width x thickness in. | Front: 15 x 4 x 0.73 Rear: 16.5 x 7 x 0.85 |
| Control | Full air dual circuit with Antilock Brake System (ABS) |
| Parking brake | Spring brake acting on rear wheels |

CAB EQUIPMENT

| | |
|--------------------------|----------------------------------------------------------------|
| Cab construction | All steel welded |
| Seating | Three-person |
| Driver's seat | Adjustable reclining, vinyl with air suspension |
| Passenger's seat | Bench type, vinyl (two passenger) |
| Seat belts | 3-point type (driver and passenger), one 2-point type (center) |
| A/C | 134 Denso |
| Heater/Defroster | 18,357 BTU/h |
| Mirrors outside rearview | Four; one flat and one convex at each side |
| Sun visors | Two – flip-down |
| Overhead compartment | Two with latching doors |
| Chrome grille | Standard |
| Ventilator | Electric forced air |
| Windshield | Laminated |
| Windshield wipers | Dual electric, 2-speed and intermittent |
| Cup holders | Standard |
| Cigarette lighter | Standard |
| Coat hook | One (rear panel) |
| Door pockets | Two |
| Air horn | Standard |
| Cruise control | Standard |

DASH INSTRUMENTATION

| | |
|----------------------------|--------------------------------------------------------------------------------------------------------------------------------------------------------------------------------------------------------------------------------------------------------------------------------------------------------------|
| Meters and gauges | Speedometer-mph (km/h) Odometer (mile) Fuel gauge Coolant temperature gauge Engine tachometer |
| Warning lamps and buzzers | Oil pressure warning lamp and buzzer Brake pressure warning lamp and buzzer Coolant level warning lamp and buzzer Battery charging system warning lamp High beam indicator lamp Turn signal indicator Parking brake warning lamp Engine control system warning lamp ABS warning lamp |
| Driver Information Display | Instant & trip fuel consumption DPR monitor Maintenance schedules Engine/vehicle diagnostics |

ELECTRICAL EQUIPMENT

| | |
|--------------------------------|----------------------------------------------|
| Batteries | Two, parallel connection, each 12 V |
| Capacity | 1200 CCA |
| Alternator | 12 V, 100 A, brush Delco |
| Starter | 12 V, 4.8 kW Denso |
| Engine shutdown system | Equipped |
| Speed limiter | Equipped |
| Audio | AM/FM radio with CD, Two speaker |
| Headlamps | Integrated with turn signal and hazard lamps |
| Stop/Tail lamps | |
| Back-up lamps | |
| Side flasher lamp | |
| Front side marker lamps | |
| Trucklite LED cab marker lamps | |
| Clearance lamps (front) | |
| Electric horn (dual) | |

CHASSIS EQUIPMENT

| | |
|-----------------|---------------------------------------------------|
| Fuel pre-filter | Davco 230 FuelPro® Heated fuel/water separator |
| Reflectors | Two rear, two front side |
| Tow hook | One at front |
| Air dryer | Heated, standard |
| Air tank | 68 L |

OPTIONS

| | |
|---------------------------------------------------------------|--|
| Cloth seats | |
| Single passenger's seat – Adjustable reclining | |
| Clutch (Dry single plate with auto adjuster –SAS 1401 Solo) | |
| Clutch (Dry twin plate with auto adjuster –SAS 1402 Solo) | |
| Cold weather package (includes) | |
| Heated mirrors | |
| Block heater | |
| Heated air dryer (Bendix) | |
| Front Bumper (Three pieces) | |
| Front Bumper (Three pieces with 4 inch extension/black) | |
| Front Bumper (4 inch extension / black) | |
| Front Bumper (chrome) | |
| Front Bumper (4 inch extension/chrome) | |
| Alternator – 12 V, 105 A, brushless | |
| Battery – 12 V GR31; GR31 x 3; GR27 x 3 | |
| Fuel tank – dual 52 gal./US; 95 gal./US | |
| Hook – two at front | |
| Tires — Front: rib, Rear: rib | |
| Locking differential with cab controls | |
| Air dryer – Bendix type without heater | |
| Rear axle – Meritor RS23-160 | |
| Exhaust system – Stack tail type; vertical stack | |
| Rear spring – with heated/non-heated shock absorbers | |
| Chrome mirrors | |
| Power windows | |
| 120k PSI frame (specific to wheelbase) | |
| Hendrickson air suspension | |
| Electric central dump valve | |
| De-rate GVW 25,950 lbs. | |
| Synthetic fluids – transmission/rear differential | |
| Cab paint – red or black | |
| Safety kit (fire extinguisher and triangle kit) | |
| Rear stabilizer | |
| Aluminum wheels | |
| Exhaust brake – Electric-pneumatic with valve in exhaust pipe | |

ROADSIDE ASSISTANCE

| | |
|------------------------------------|--------------------------------------------------------------------------------------------------------------------------------------------------------------------------------------------------------|
| HinoWatch (service free of charge) | 3-year unlimited roadside assistance <ul style="list-style-type: none"> • Lockout • Out of Fuel • Battery Jumpstart • Information • Warranty Towing |
|------------------------------------|--------------------------------------------------------------------------------------------------------------------------------------------------------------------------------------------------------|

NOTE:

All specifications of the products are with normal manufacturing allowances and tolerances. HINO MOTORS SALES U.S.A., INC. reserves the right to alter specifications at any time without previous notice. Some optional items may require extra lead time.